



**Series 3600
Concealed Vertical Rod
Exit Devices**

www.firstchoicebuildingproducts.com
Ph: 800-793-4544

TO INSTALL VERTICAL ROD LATCHES

(Rods are factory preset for door height of 83 3/16" and a cylinder location of 41 5/16" - see page 4 for additional details.)

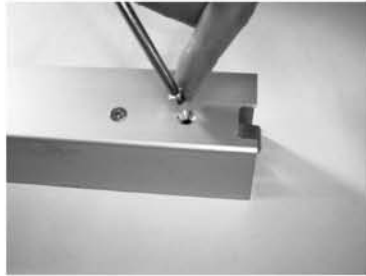

Install top latch mechanism using 2 ea. #10-32x1/4" screws.



Affix bent end of rod to door using rod bushing with "E" ring.

INSTALL BOTTOM ROD ASSEMBLY IN THE SAME MANNER AS ABOVE.

TO INSTALL ACTIVATING DEVICE

Prepare door as per template on page 8.

Install the hinge stile mounting bracket with 2 ea. 1/4-20 x 1/2" pan head screws leaving space to capture the base of the device (see next step).



TO INSTALL ACTIVATING DEVICE CONTINUED

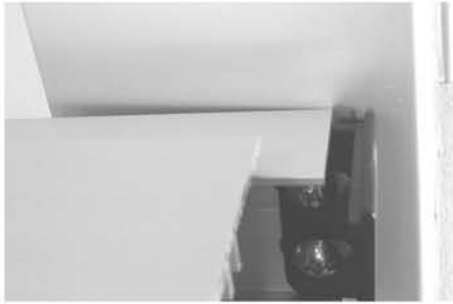

Fig. A



Fig. B

Slip the device base under the mounting bracket (Fig. A) and attach device to the lock stile with 2 ea. $\frac{1}{4}$ -20x $\frac{1}{2}$ " flat head screws (Fig. B). Tighten all four $\frac{1}{4}$ -20 screws to secure the device.

With the traveler positioned as shown, locate it over the rod ends.

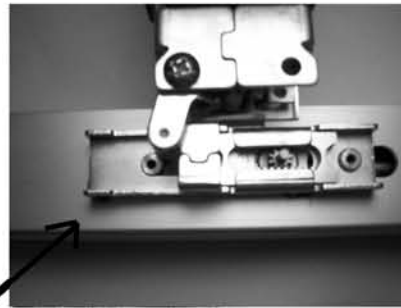

TRAVELER

CHECK ROD OPERATION



After dogging the device –

When tripped by hand, **the top latch** should swing freely through it's travel.

If not completely free, lengthen the top rod by loosening the jamb nut and rotating the rod counter-clockwise.

The **bottom latch** should protrude $\frac{1}{16}$ " or less beyond the bottom of the door.

To shorten the bottom rod, loosen the jamb nut and rotate the rod clockwise.

CHECK ROD OPERATION CONTINUED

After un-dogging the device –

The top latch should **not** trip when operated by hand. If hand pressure can trip the latch, shorten the rod by loosening the jamb nut and rotating the rod clock-wise.

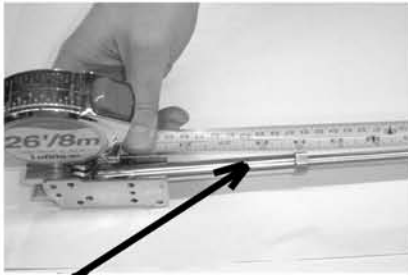

34 1/4"

The top rod is factory set to 34-1/4" measured from the bent end to the latch side of the jamb nut.

NOTE–The bottom rod may require adjustment to accommodate changes to the top rod.

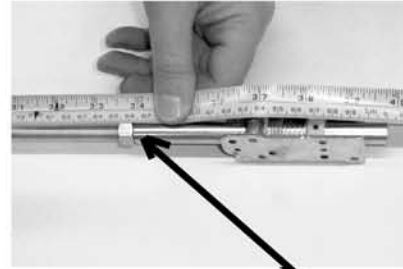

34 1/16"

The bottom rod is factory set to 34-1/16" measured from the bent end to the latch side of jamb of jamb nut.

FOR DEVICES WITH KEY CYLINDER

Prepare doors with cylinder holes as per template on page 8.

Trim the cylinder tail piece so that it is slightly below the door face after mounting.

Install key cylinder using mounting screws supplied with the cylinder. (The screws may need to be shortened.)



TRIMMED TAILPIECE.

Install the pinion gear and bushing with the indicator edge up. This will align the slots to match the tail piece.

ALIGN FLAT SIDE TO
TOP OF DOOR.

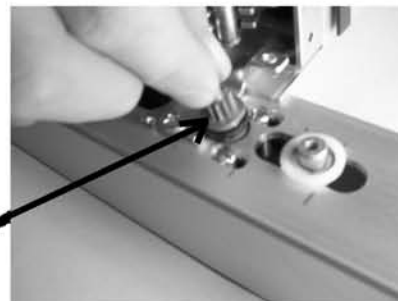

FOR DEVICES WITH KEY CYLINDER CONTINUED

With the retractor installed into the traveler, position the **retractor** over the pinion gear and position the **traveler** over the rod ends. (Temporarily removing the crank roller may facilitate this procedure.)

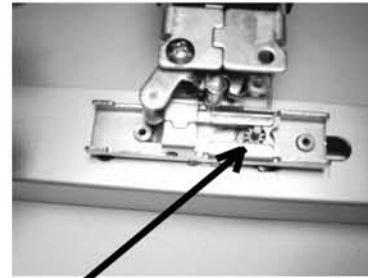

(SETTING FOR HOLD BACK)

Set retractor at the top of rotation for cylinder Hold Back function, or set it midway along the rotation for Night Latch function.

Proceed to next step to secure pinion gear.

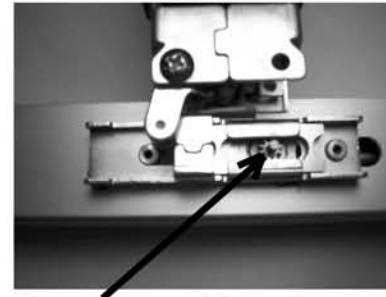

(SETTING FOR NIGHT LATCH)

TO SECURE THE PINION GEAR:

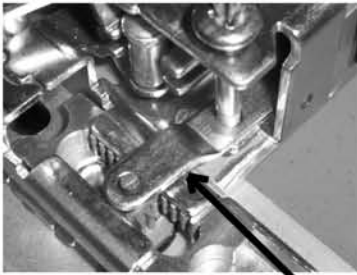

PINION RETAINER

Install the pinion retainer over the pinion and onto the crank bracket using an axle screw.

COMPLETING THE INSTALLATION:



Mount the inactive side end cap using 2 ea. #8-32 x 1 1/2" screws.



Install active side cover using two each #10-32 x 3/8" screws.

TO CHANGE HAND OF DEVICE:



Remove the crank roller assembly axle screw from crank bracket.



Flip the crank roller assembly over and locate on the opposite side of the crank bracket. Reattach with the axle screw.

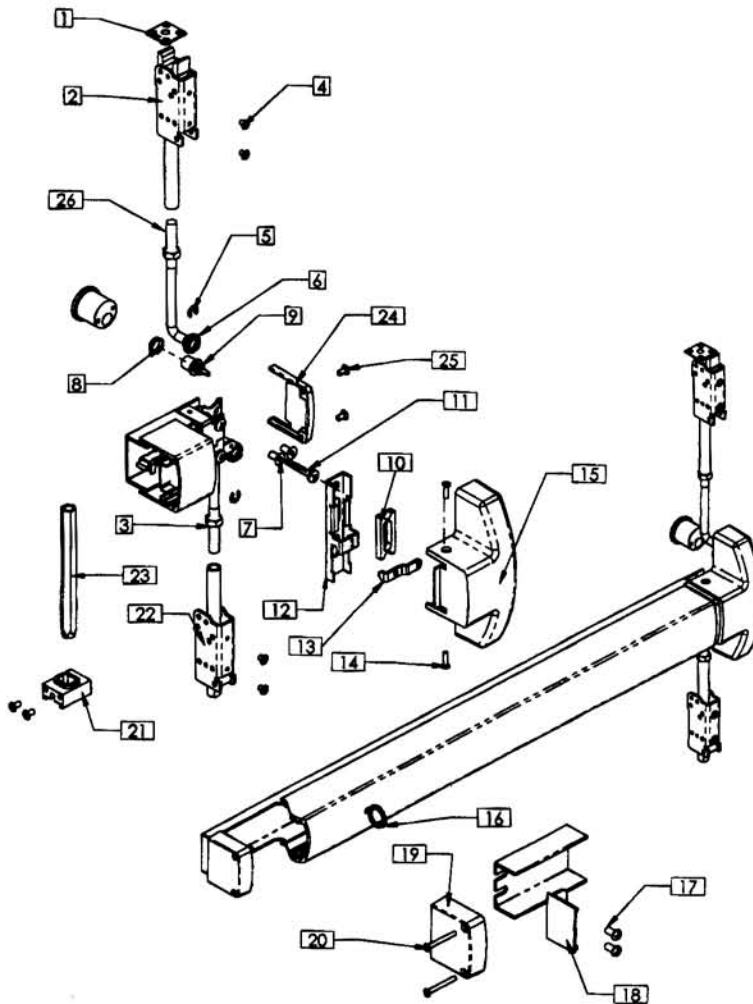

<i>Reference Number</i>	<i>Description</i>	<i>Part Number</i>	<i>Quantity Per Device</i>
1	Top Strike Kit - SS	9038	1
	Consists of:		
	Top Strike (1 ea.)	16001238	
	Strike Shim (3 ea.)	16001118	
2	Top Latch Assembly	42	1
3	Jamb Nut	806	2
4	Latch Housing Screw	811-CL , 811-BR	4
5	Retaining E-Ring	809	2
6	Rod Bushing	810	2
7	Lock Stile Mounting Screw	816	2
8	Cylinder Bushing	16001004	1
9	Pinion	16001007	1
10	Retractor	16001003	1
11	Axle Screw	3	1
12	Traveler	16001098	1
13	Pinion Support Bracket	821	1
14	Cover Screw	804	2
15	Center Case Cover	40	1
16	Dogging Key	819	1
17	Hinge Stile Mounting Screw	801	2
18	Channel End Cap	33	1
19	Hinge Stile Push Bar End Cap	30	1
20	End Cap Mounting Screw	802	2
21	Weighted Latch Guide w/ Screws	77	1
22	Bottom Latch Assy - Spring	45	1
23	Bottom Latch Assy - Weighted	76	1
24	Lock Stile End Cap	50	1
25	LS End Cap Mounting Screw	838	2
26	Vertical Rod w/ locking nut	16001015	2

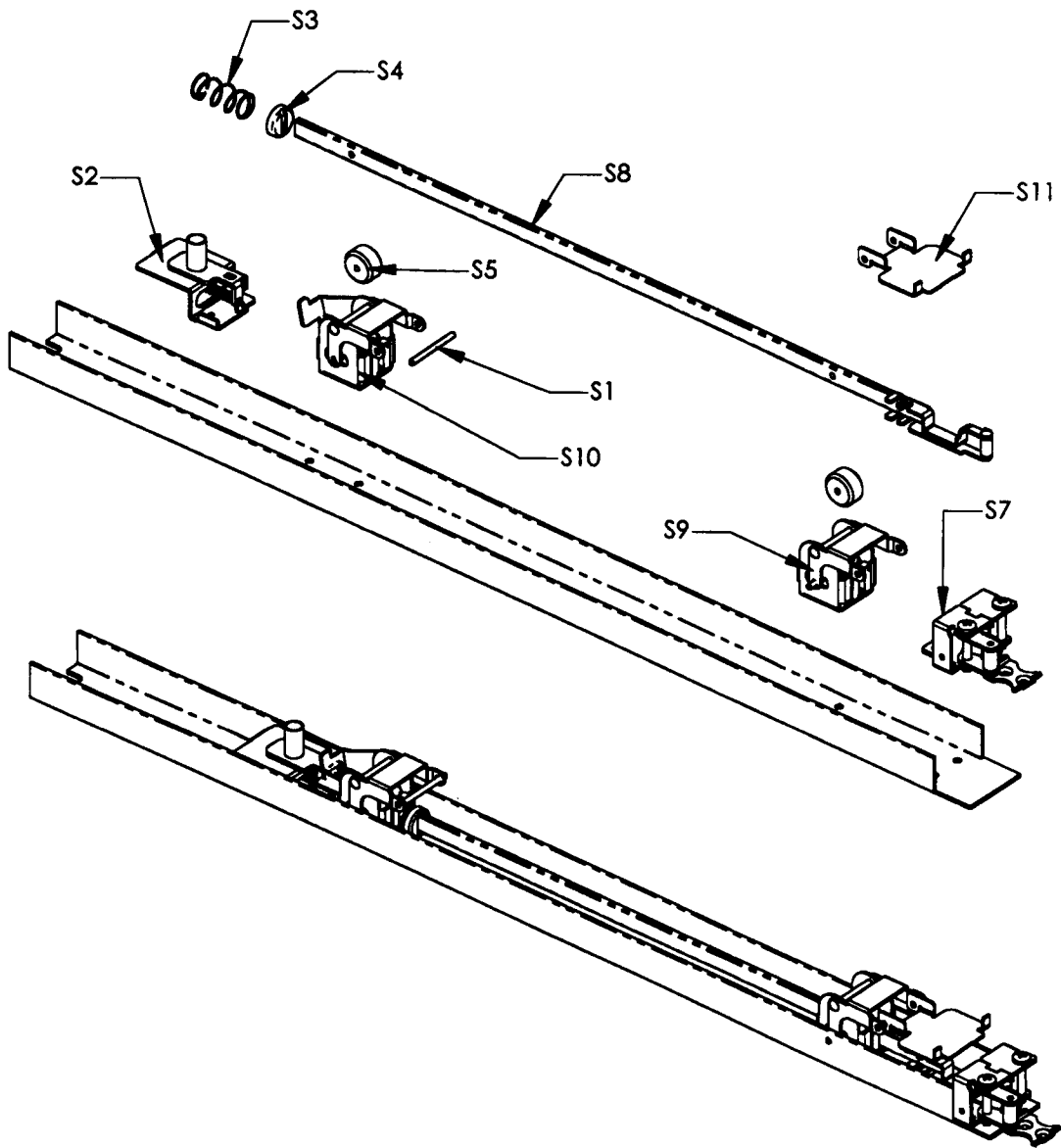

Reference Number	Description	Part Number	Quantity Per Device
S1	Axle Pins	14	2
S2	Dogging Assy.	71	1
S3	Spring	23	1
S4	Spring Cap	24	1
S5	Roller Stop	17	2
S7	Crank Bracket Assy.	9040	1
S8	Activating Connecting Rod	21	1
S9	Lock Stile Activating Bracket	9034	1
S10	Hinge Stile Activating Bracket	70	1
S11	Push Bar Bracket	15	1

ADDITIONAL ITEMS NOT REFERENCED -

	<i>Bottom Rod & Latch Assy - Spring</i>	9045	1
	<i>Bottom Rod & Latch Assy - Weighted</i>	9076	1
	<i>Pullman Top Latch For Electric Strike</i>	P42	1
	<i>Top Rod & Latch Assy.</i>	9042	1
	<i>Push Bar Assy - x Long - Clear</i>	360036-CL	1
	<i>Push Bar Assy - x Long - Bronze</i>	360036-BR	1

Concealed Vertical Rod Panic For Bottom Rod Latch Installation Template

All prep is on interior side of door, except where noted.
Right Hand door shown. (LHRB)

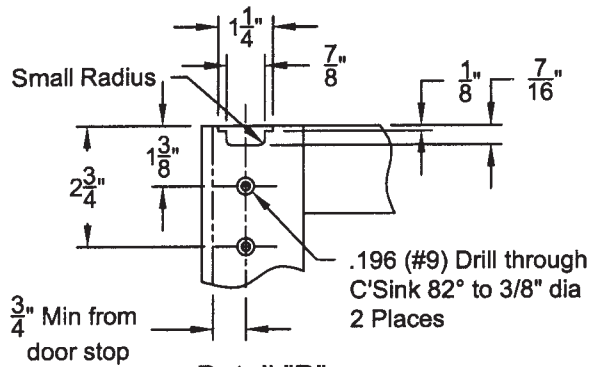

Detail "D"
Top Latch
Cutout inside face only!

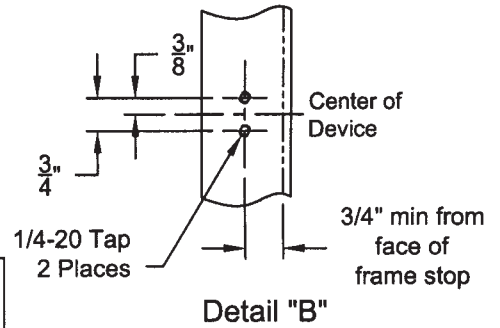

Detail "B"

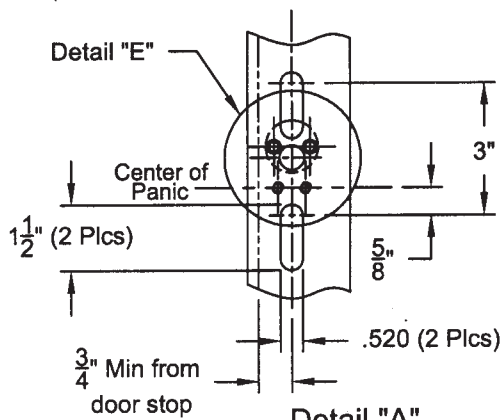

Detail "A"

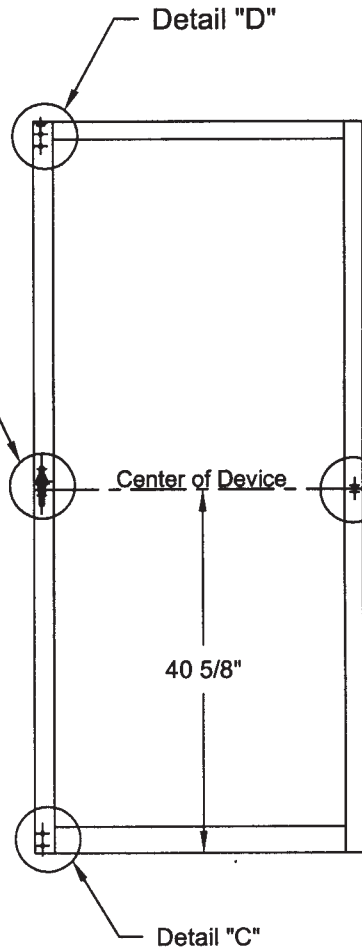

.196 (#9) Drill through C'sink 82° to 3/8" dia 2 Places

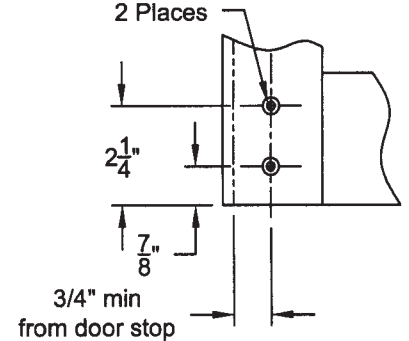

Detail "C"
for Rod Latch

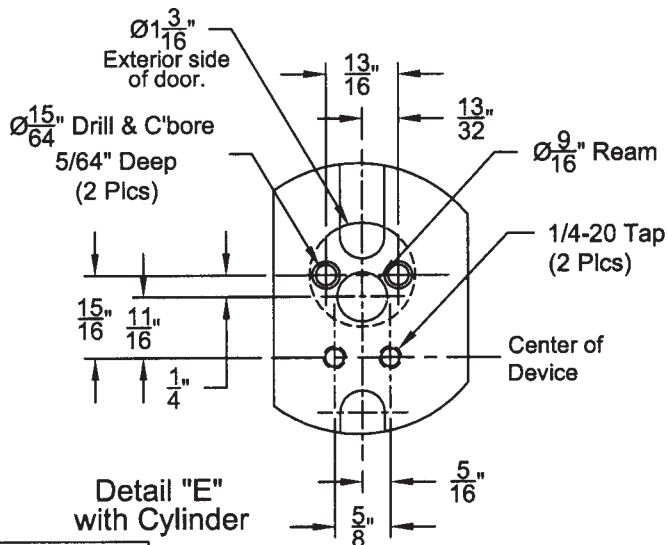

Detail "E"
with Cylinder

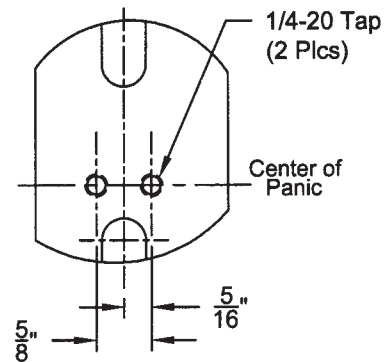

Detail "E"
without Cylinder